

Version VI
A-A

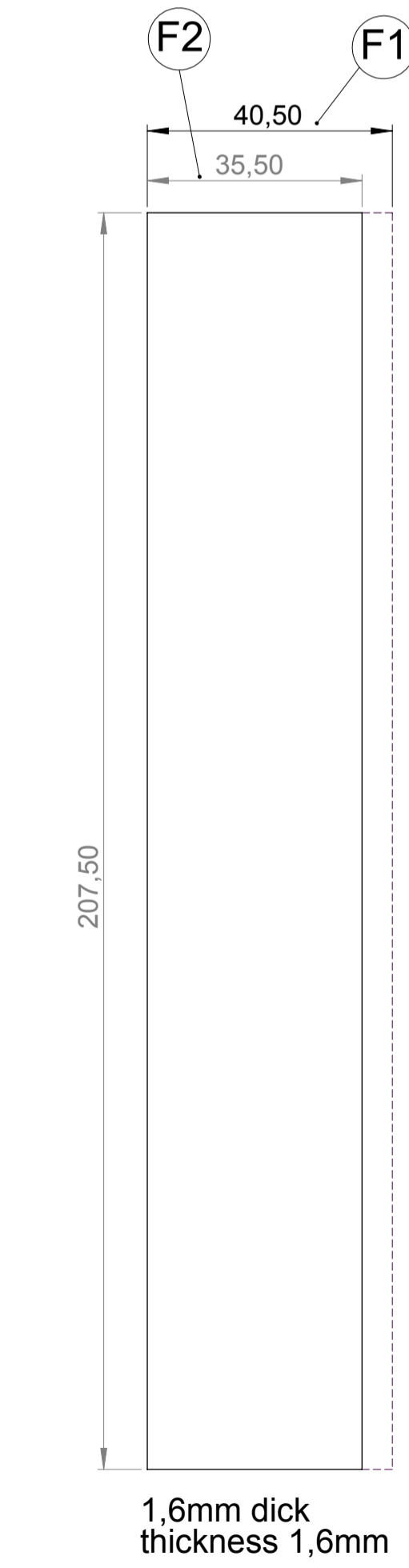
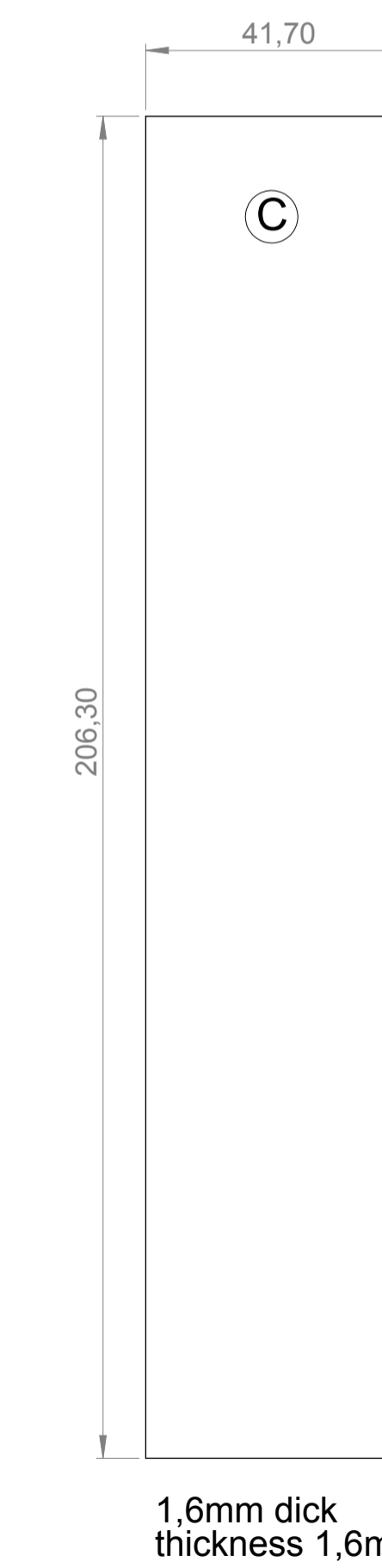
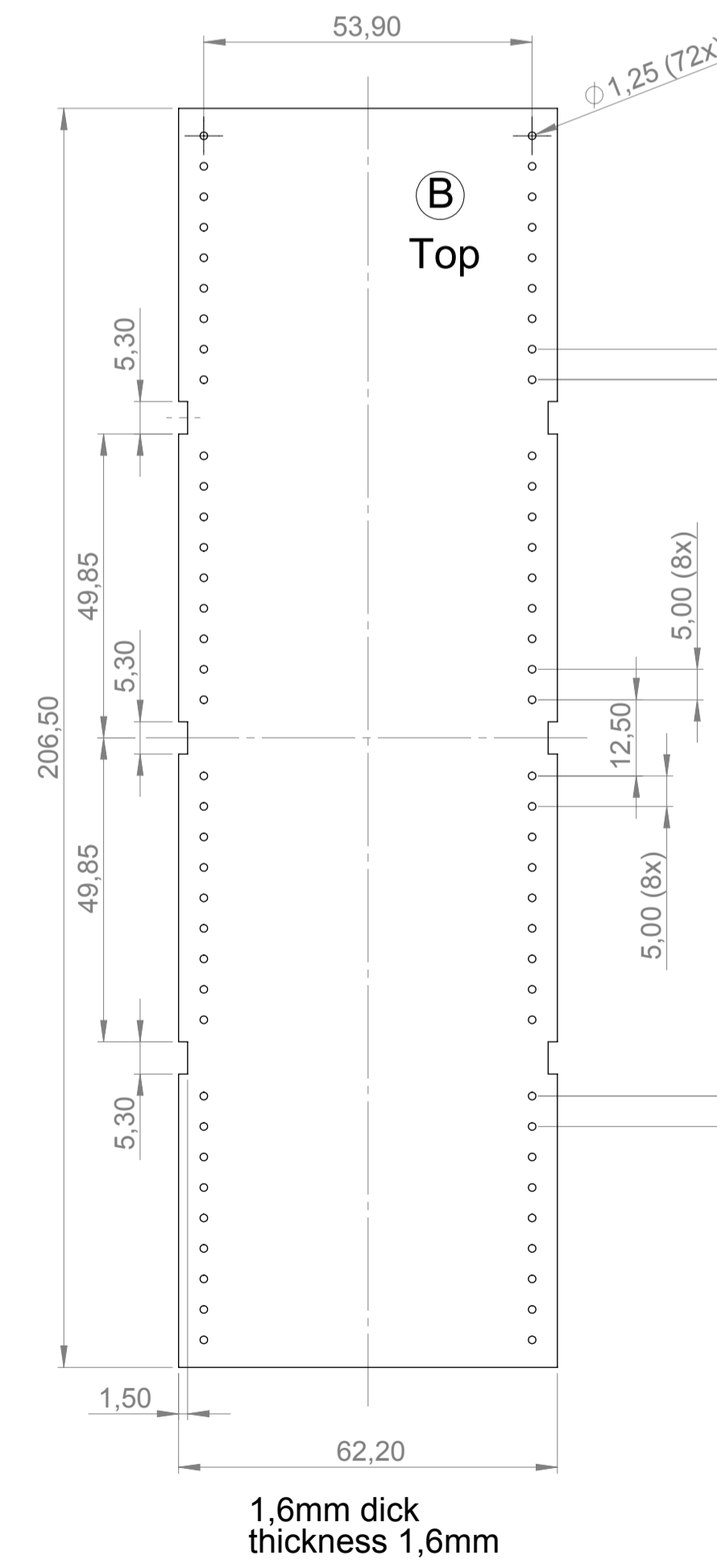
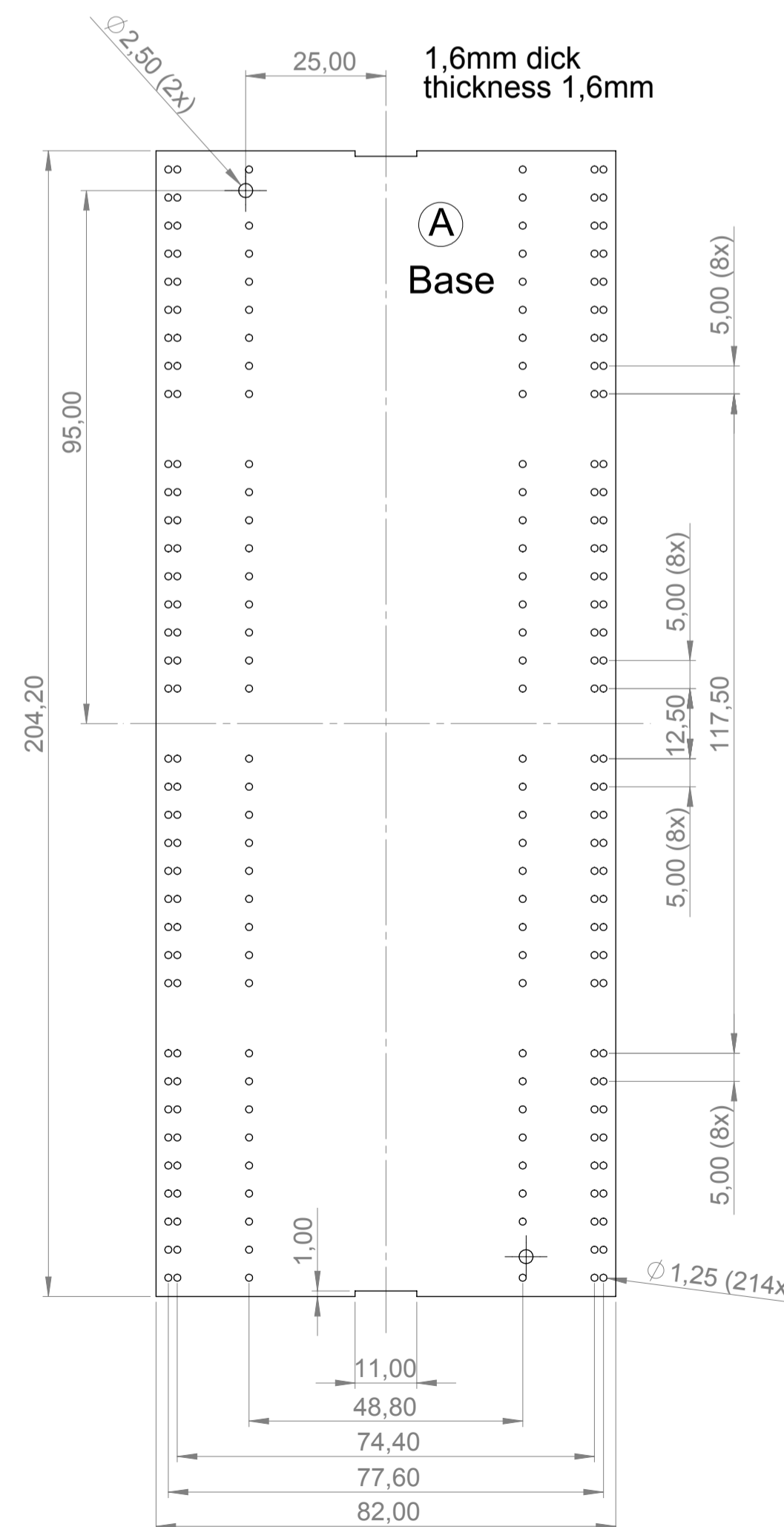
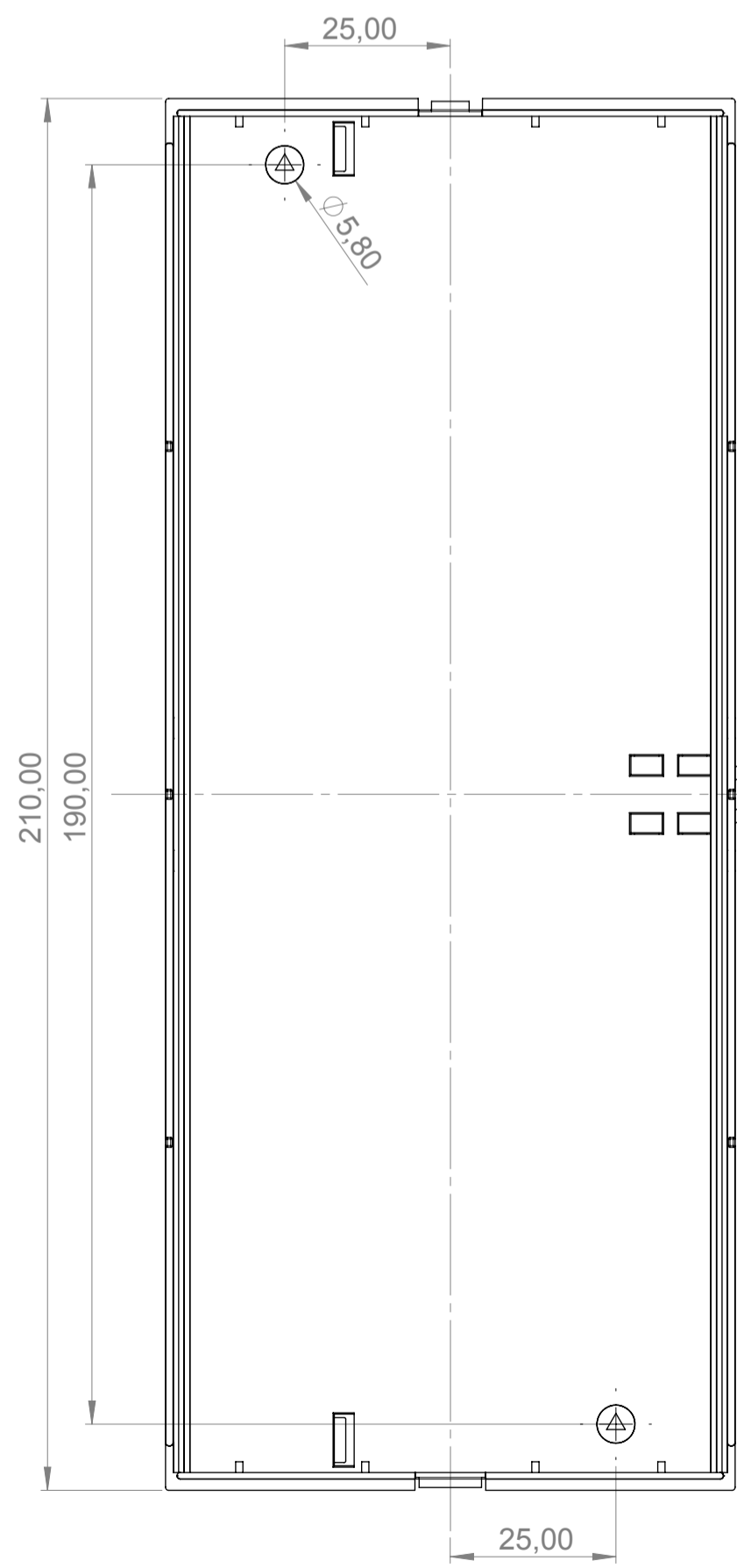
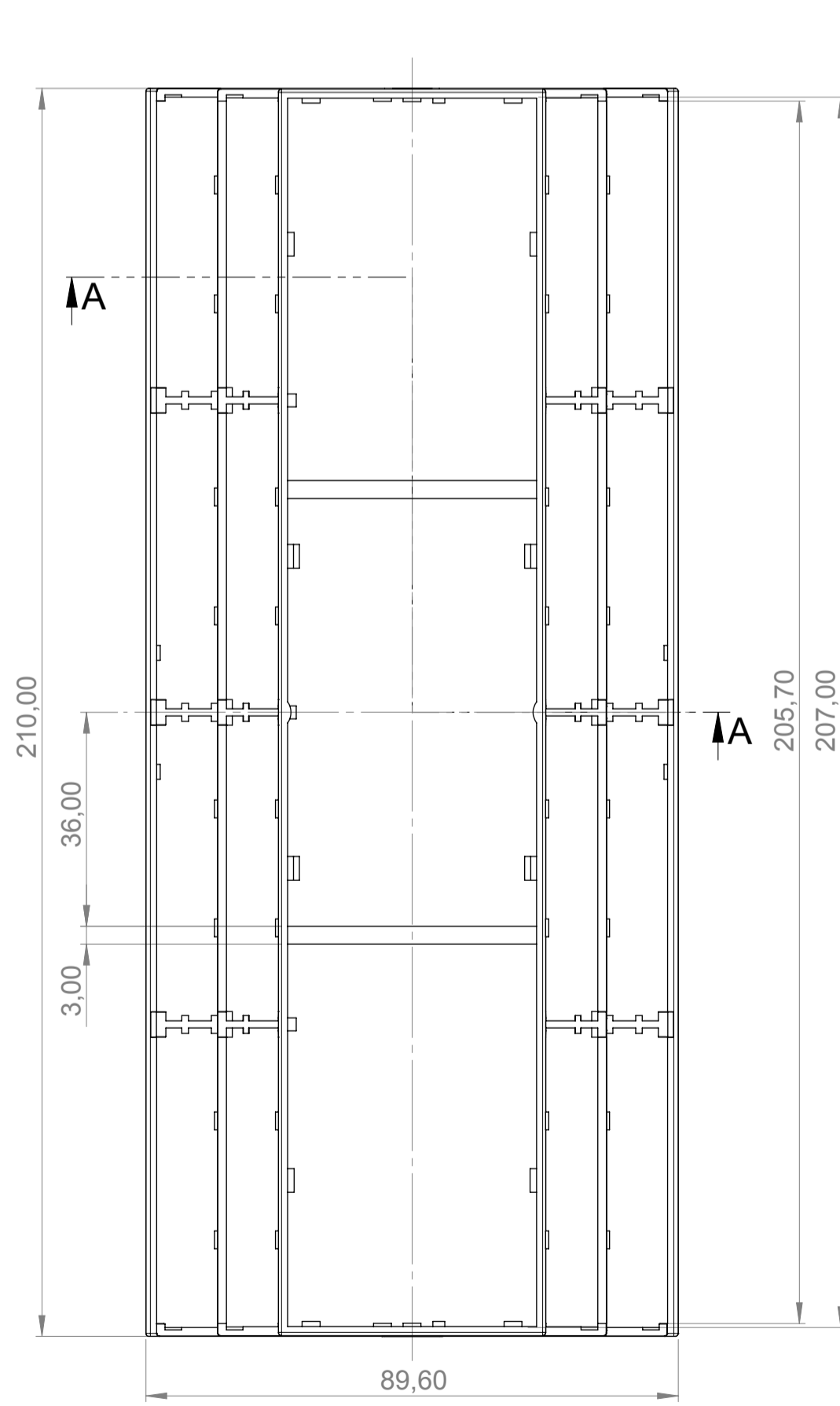
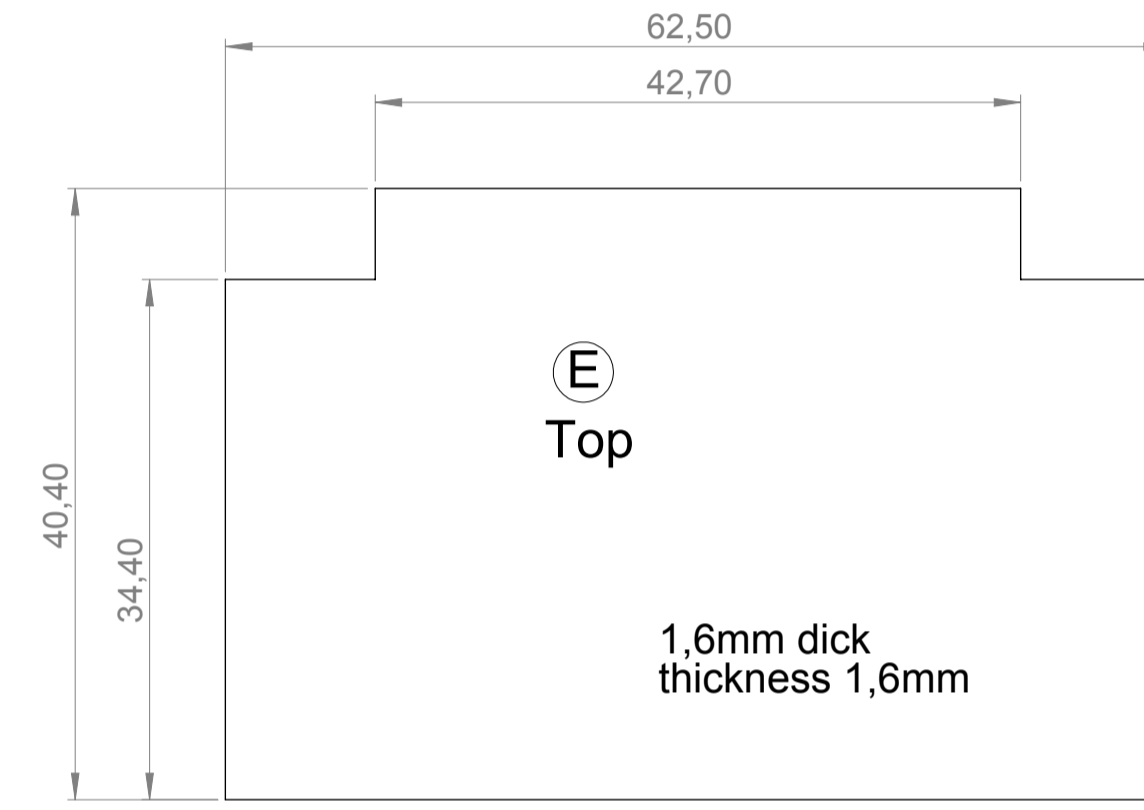
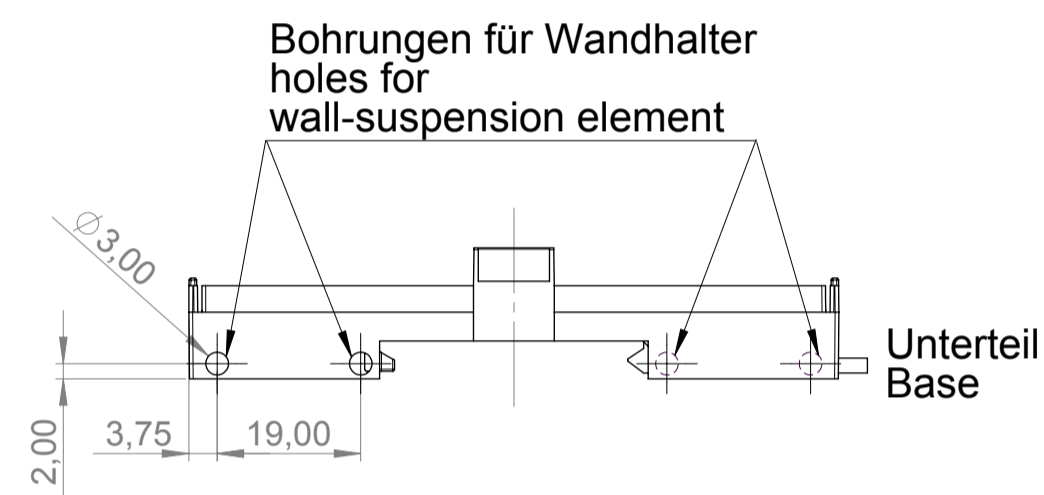
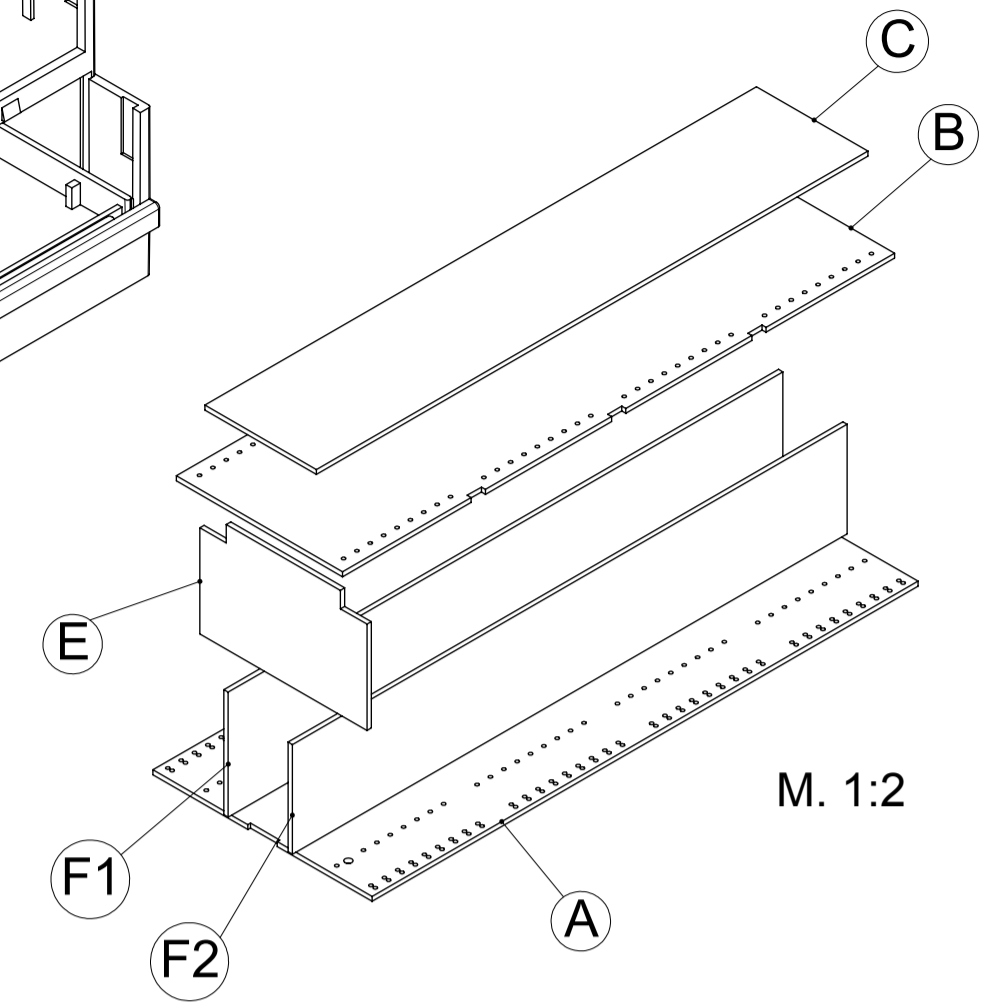
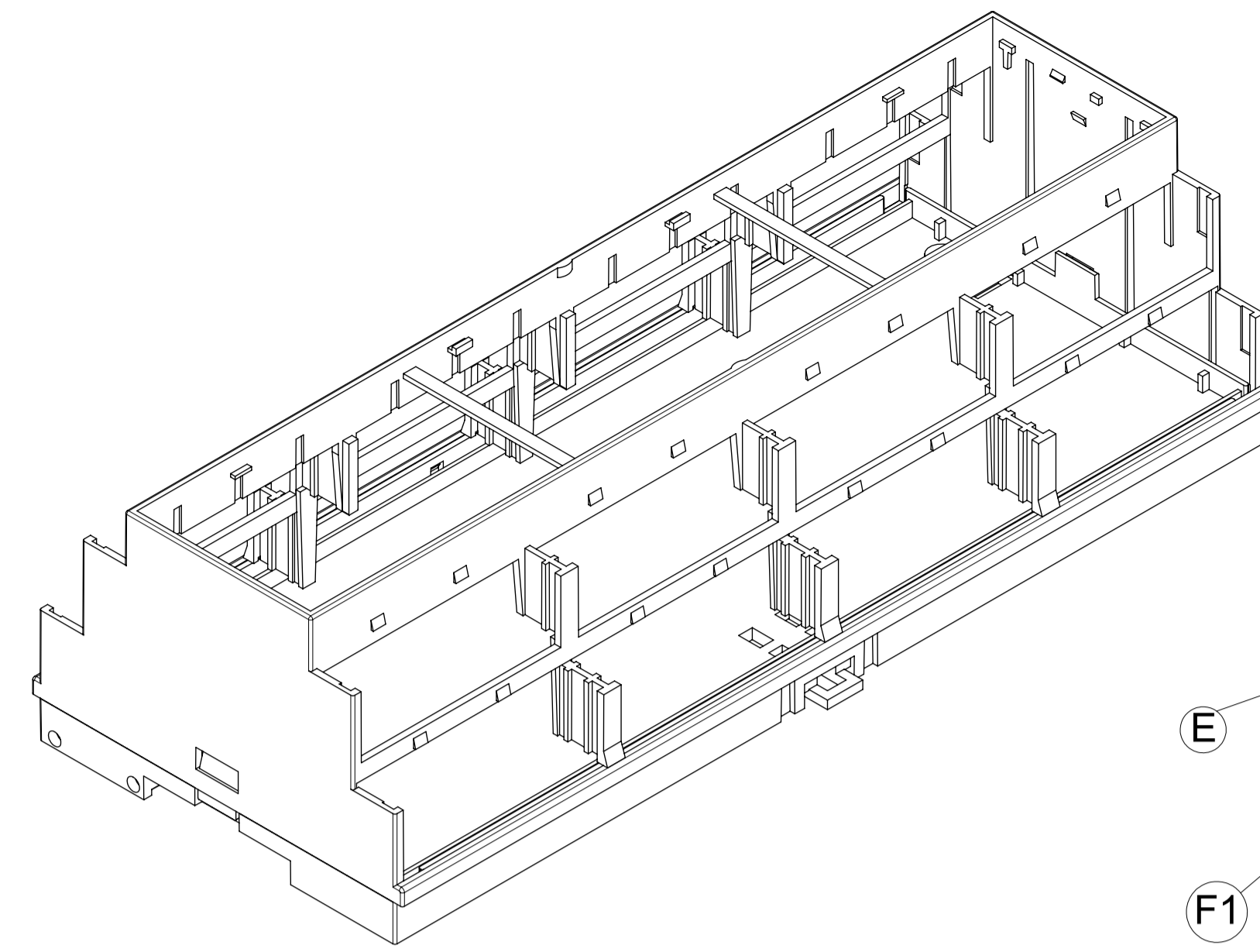
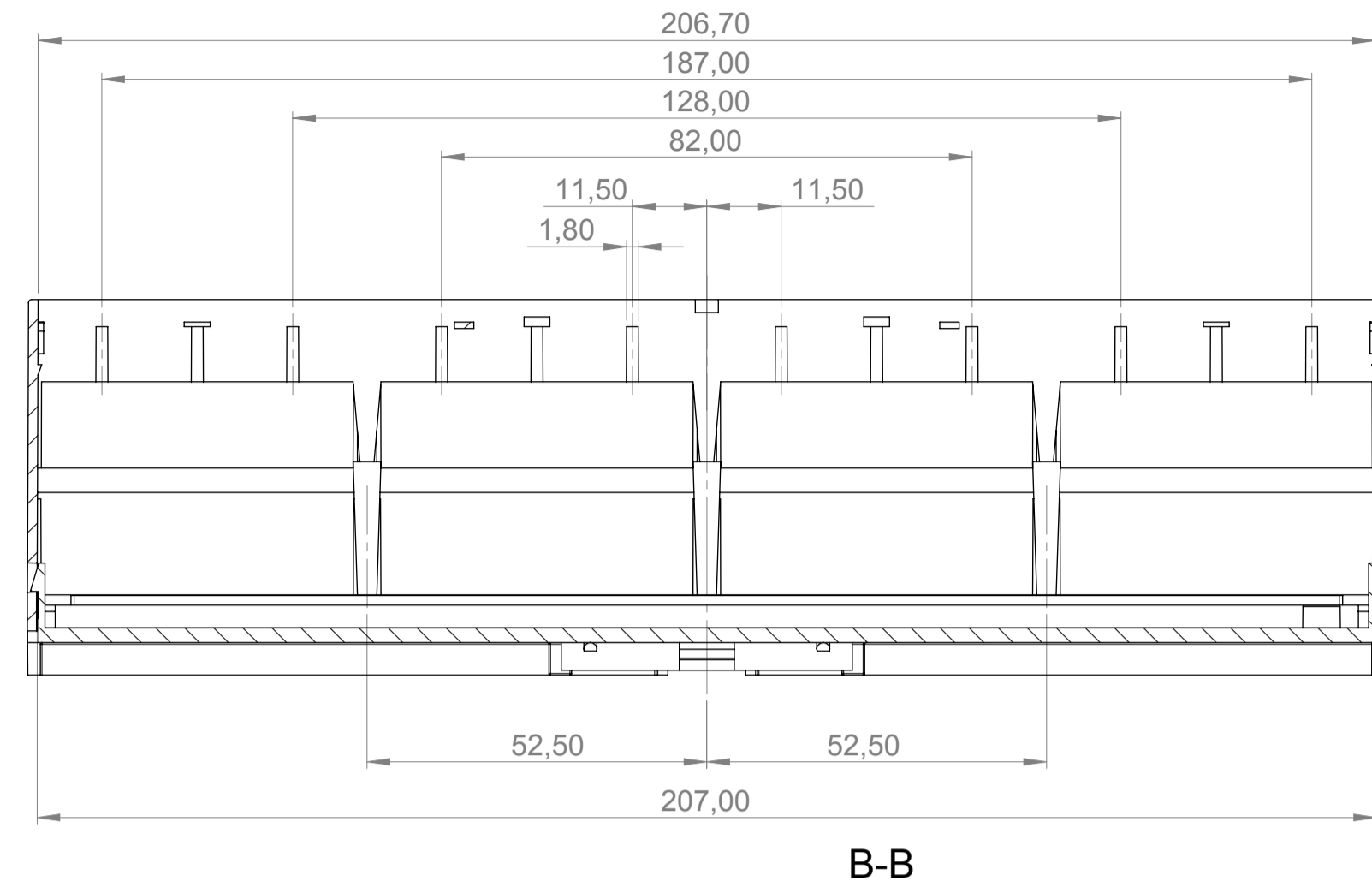
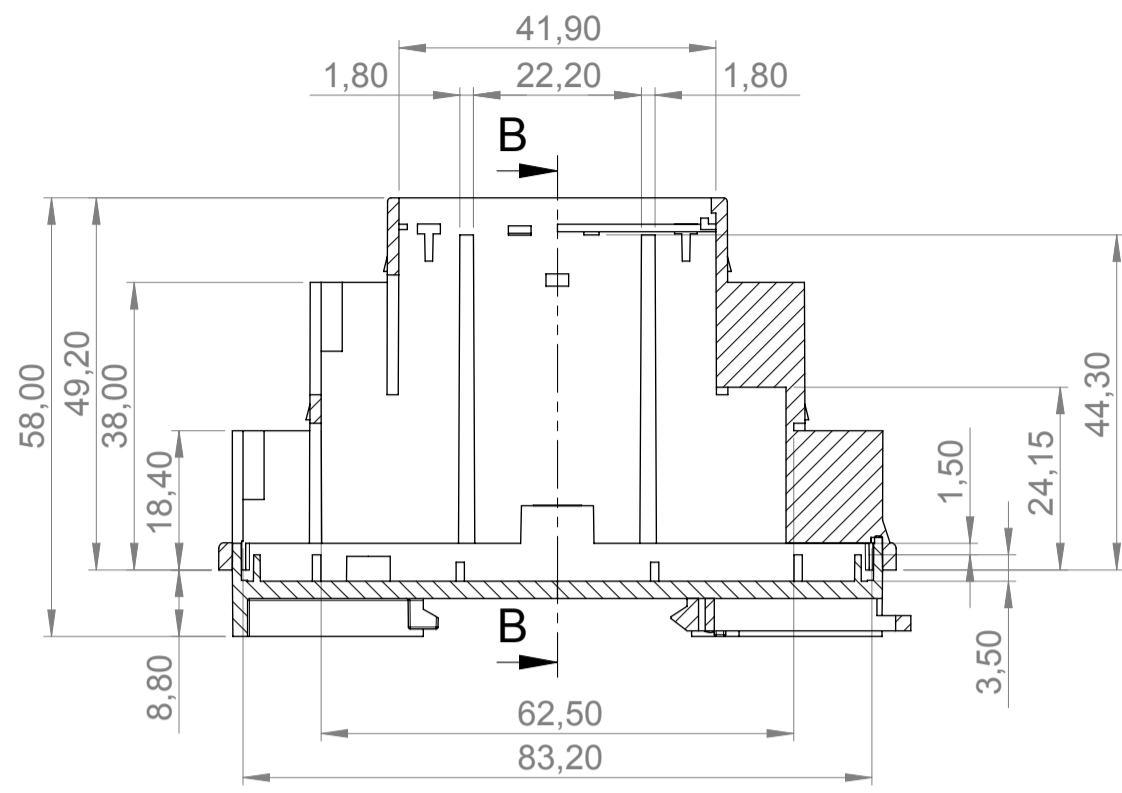

Informationskopie wird nicht aktualisiert Copy for information will not be updated	Bearb. am: 06.06.07 Ersteller: Hasselb Freigabe: Weinlein Rev. Index: 1 Stand: 07.04.08	Material: Farbe: Zeichnungsart: KUNDE	Toleranzen: DIN 16901 T130 Zeichnungsart: KUNDE	DIN 6 Teil 2 1:1
	Technische Änderungen vorbehalten. Inhaber oder Druckfehler begründen keinen Anspruch auf Schadensersatz. Wichtige Einbaumaße sind direkt mit dem aktuellen Produkt abstimmen. Subject to technical modifications without prior notice. Typographical and other errors do not justify any claim for damages. All dimensions should be verified using an actual moulded part. Sous réserve de modifications techniques. Toute erreur ou faute d'impression ne justifie aucune demande d'indemnisation. Nous prions les clients de vérifier les dimensions des composants avec les boîtes avant le montage.			
	Für dieses Dokument behalten wir uns alle Urheberrechte vor. Es darf auch auszugsweise weder vervielfältigt noch Dritten in irgendeiner Form zugänglich gemacht werden.			