

Freisparung für Schrauben der Platine ①
cutout for PCB screws

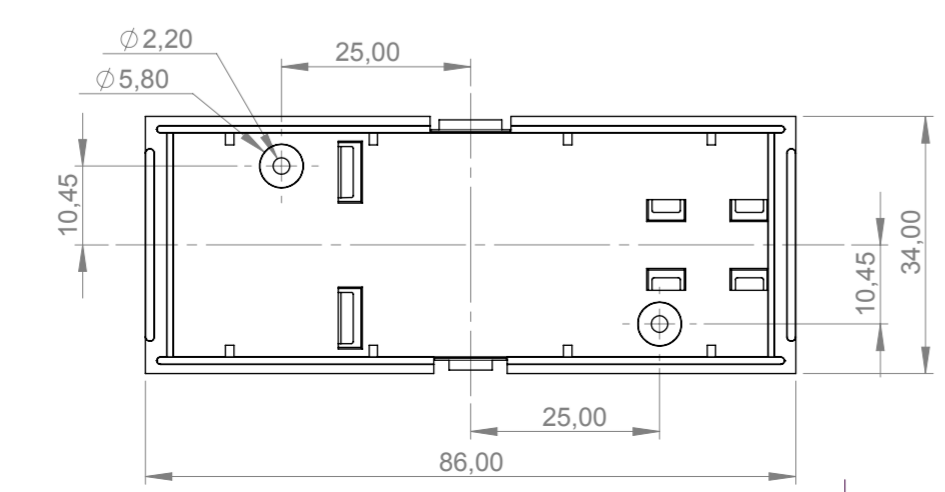
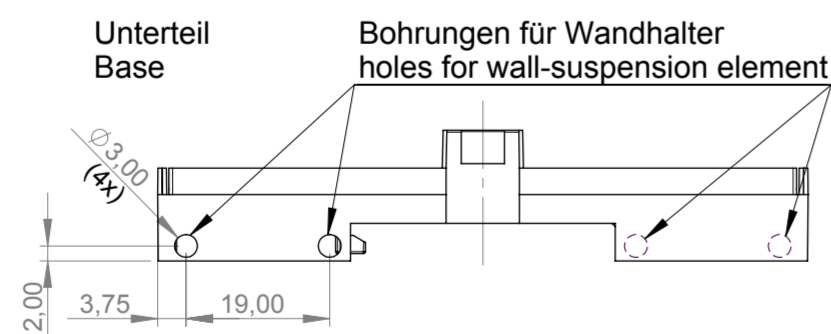

<p>Informationskopie wird nicht aktualisiert Copy for Information will not be updated</p> <p><small>Technische Änderungen vorbehalten. Irrtümer oder Druckfehler begründen keinen Anspruch auf Schadenersatz. Wichtige Einbaumaße bitte direkt mit dem aktuellen Produkt abstimmen. Subject to technical modification without prior notice. Typographical and other errors do not justify any claim for damages. All dimensions should be verified using an actual moulded part. Sous réserve de modifications techniques. Toute erreur ou faute d'impression ne justifie aucune demande d'indemnisation. Nous priions les clients de vérifier les dimensions des composants avec les boîtiers avant le montage.</small></p>	<p>Bearb. am: 25.02.08 Ersteller: Hasselb Freigabe: Schaal Rev. Index: 2 Stand: 20.10.08</p>	<p>Material: Farbe:</p>	<p>Toleranzen: DIN 16901 T130 Zeichnungsart: KUNDE</p>	<p></p> <p>DIN 6 Teil 2 Maßstab: 1:1 Bearbeiter: Hasselb Dateiname: 00010352</p>
	<p></p>	<p>This document contains proprietary information of OKW Gehäusesysteme GmbH and is tendered subject to the conditions that the information be retained in confidence not be reproduced or copied and not be used or incorporated in any product.</p>		
<p>RAILTEC B 2 Module Version I - V B650111*</p>			<p>Für dieses Dokument behalten wir uns alle Urheberrechte vor. Es darf auch auszugsweise weder vervielfältigt noch Dritten in irgendeiner Form zugänglich gemacht werden.</p>	